



OIL TRAP, CRANKCASE BREATHER

V10-2595 | 06H 103 495 E*

AIR CONTROL SYSTEMS | 11207



SYMPTOMS

- Hose is hard to snap-on



REASONS FOR FAILURE

- Dry o-rings



RECOMMENDED BY THE EXPERTS

- Use **silicone spray** for dry o-rings before assembling
- Replace the oil separator and the hoses every 60,000 – 100,000 kilometers
- Replace the ventilation and hoses every third oil change

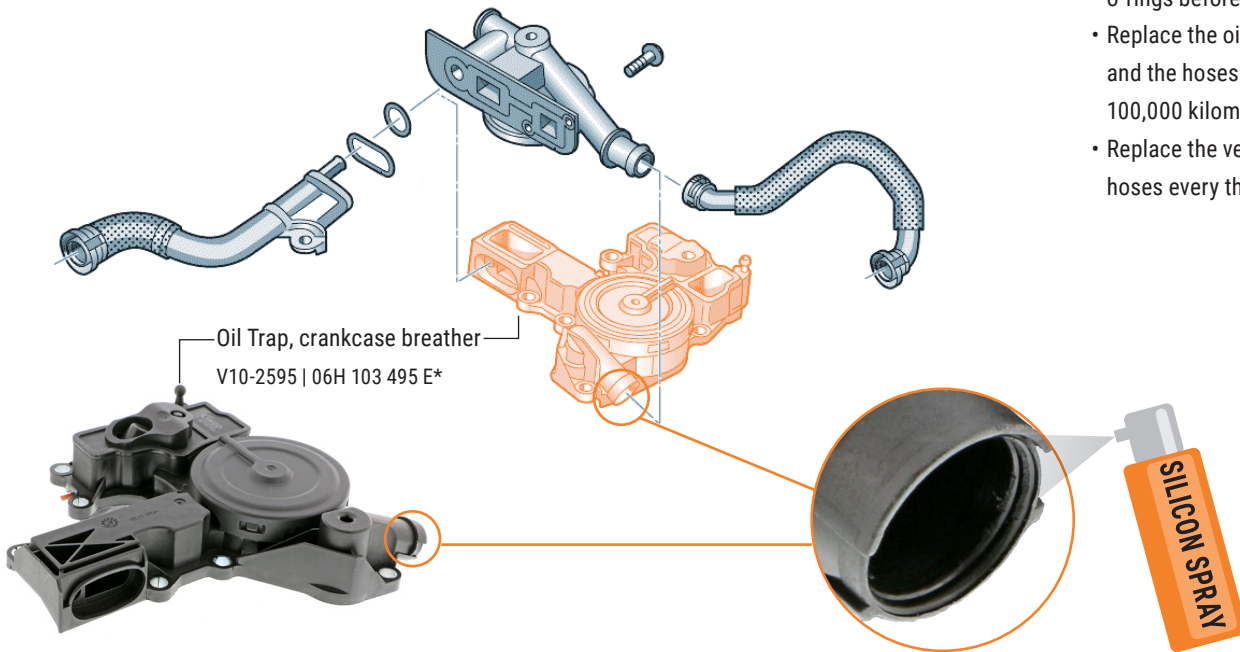

DID YOU KNOW?

- VAICO offers a **practical repair set** including oil separator and hoses:
Expert Kits+ V10-3881
- **High quality material:** Plastic PA6 GF30, PA6 GF25 according to OE standards, high quality FMP seals
- **State of the art production technics:** optimal welding processes to ensure the components' life-span

HOSES + VALVE =

REPAIR SET, CRANKCASE BREATHER



Audi	A3, TT
VW	Jetta, Beetle, Passat, Tiguan
Consists of	V10-2595 (06H 103 495 E*), V10-3879 (06J 103 213 D*), V10-3880 (06J 103 221 A*)
X-Ref	06A 103 495 AC kit* V10-3881

* For detailed vehicle information, please refer to the vehicle lists under www.autoteile.de.

Notes: Temporary offers are only valid while stocks last. All offers remain subject to prior sale. Our general terms and conditions of sale and delivery as well as our warranty conditions apply, which are available for download on our website. All prices are net prices. Errors excepted. Reference numbers and names, with the exception of VIEROL AG, are for comparison only and may not be disclosed in invoices. They are non-binding and no indication of origin. © VIEROL AG



OIL TRAP, CRANKCASE BREATHER

V10-2595 | 06H 103 495 E*

AIR CONTROL SYSTEMS | 11207



SYMPTOMS

- Leaking hoses



REASONS FOR FAILURE

- Small gasket is the main reason for leaking problems



RECOMMENDED BY THE EXPERTS

- When replacing the oil separator, **always change the hose (06J 103 213 D*) or the gasket**
- Replace the oil separator and the hoses every 60,000 – 100,000 kilometers
- Replace the ventilation and hoses every third oil change

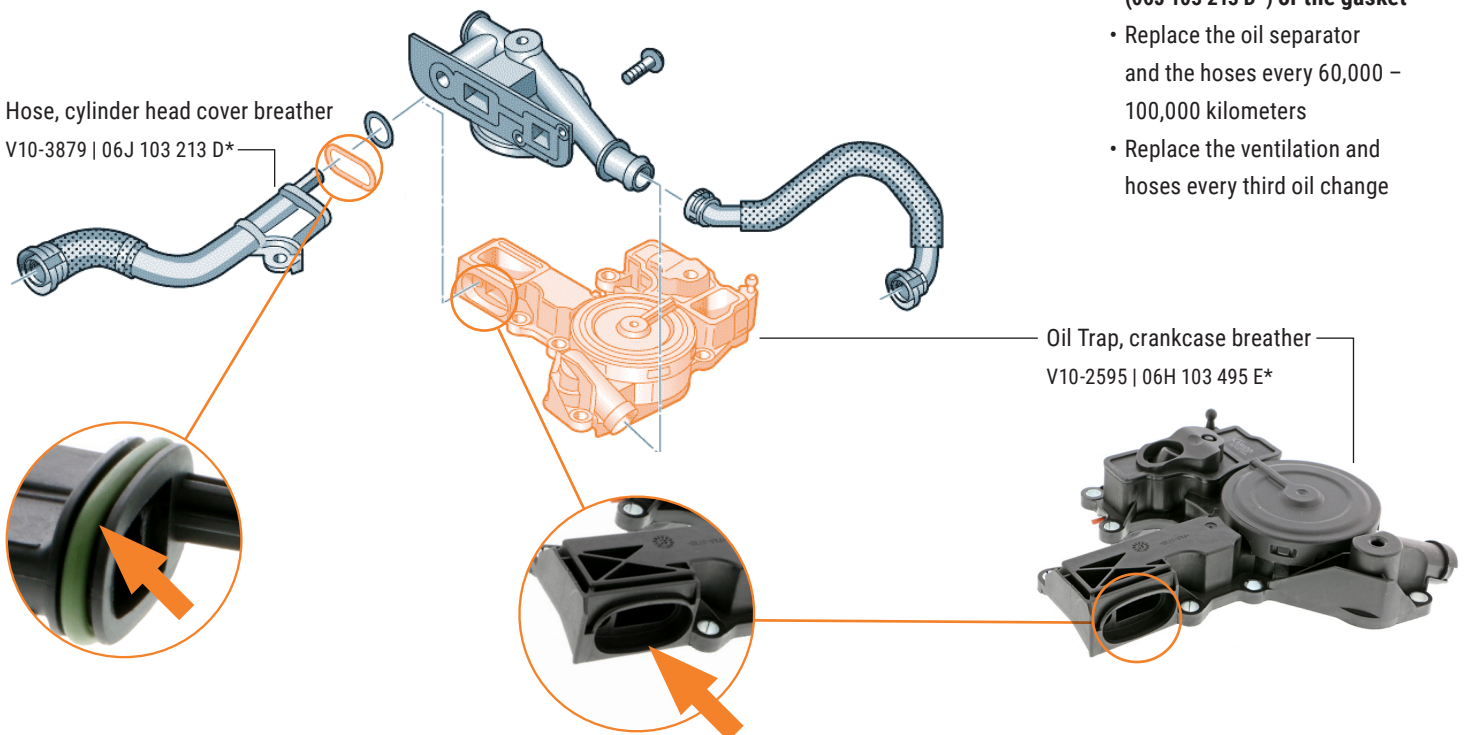

DID YOU KNOW?

- VAICO offers the fitting hose, including the gasket: **V10-3879**
- **High quality material:** Plastic PA6 GF30, PA6 GF25 according to OE standards, high quality FMP seals
- **State of the art production technics:** optimal welding processes to ensure the components' life-span
- **Practical repair sets:** including bleeder valves and fitting hoses

HOSE, CYLINDER HEAD COVER BREATHER



Audi	A3, TT
VW	Jetta, Beetle, Passat, Tiguan
Info	with gasket, Original VAICO Quality
X-Ref	
06J 103 213 D*	V10-3879

* For detailed vehicle information, please refer to the vehicle lists under www.autoteile.de.

Notes: Temporary offers are only valid while stocks last. All offers remain subject to prior sale. Our general terms and conditions of sale and delivery as well as our warranty conditions apply, which are available for download on our website. All prices are net prices. Errors excepted. Reference numbers and names, with the exception of VIEROL AG, are for comparison only and may not be disclosed in invoices. They are non-binding and no indication of origin. © VIEROL AG